

### 3501 Power Supply

The 3501 power supply is adjustable from +/- 2.5VDC to +/- 18VDC at about 1.5 amps, with proper a proper heat sink.

EFM kits are designed for +/- 12VCD operation.

The 3501 uses the LM317 and LM377 voltage regulators. The kit contains separate snap-on T0-220 heat sinks but for the best heat transfer use a larger piece of aluminum and heat transfer compound. This supply will easily power a small modular.

**CAUTION:** The cases are not at the same potential and mica insulators must be used if they are mounted on the same heatsink.

### LINE VOLTAGE WARNING

This project uses a line voltage transformer. **BEFORE plugging the transformer into the wall** be sure all connections are insulated and you are clear of all conductors. Failure to follow these instructions could result in **INJURY OR DEATH**. Be careful!!

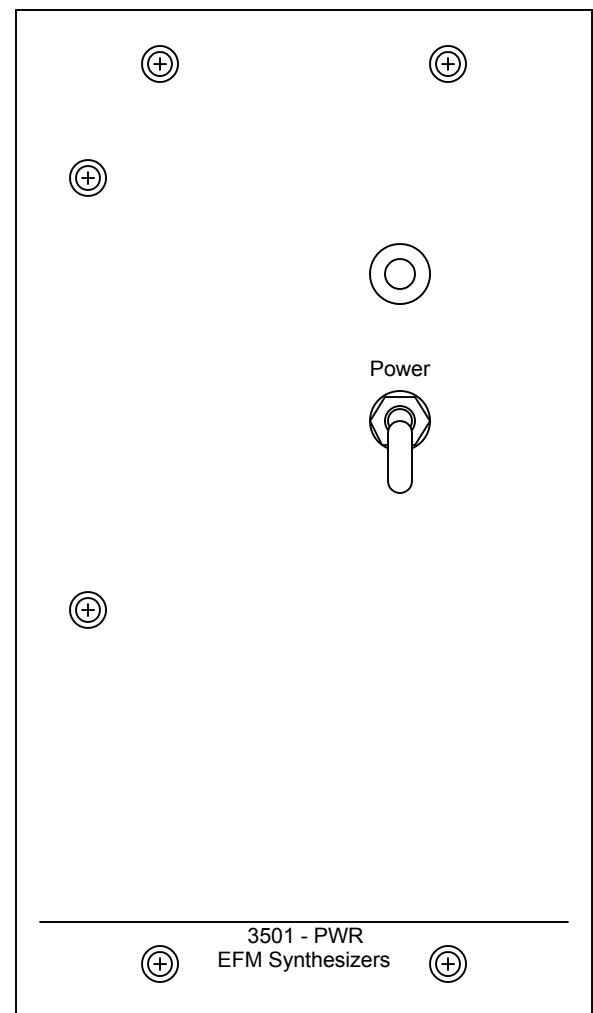
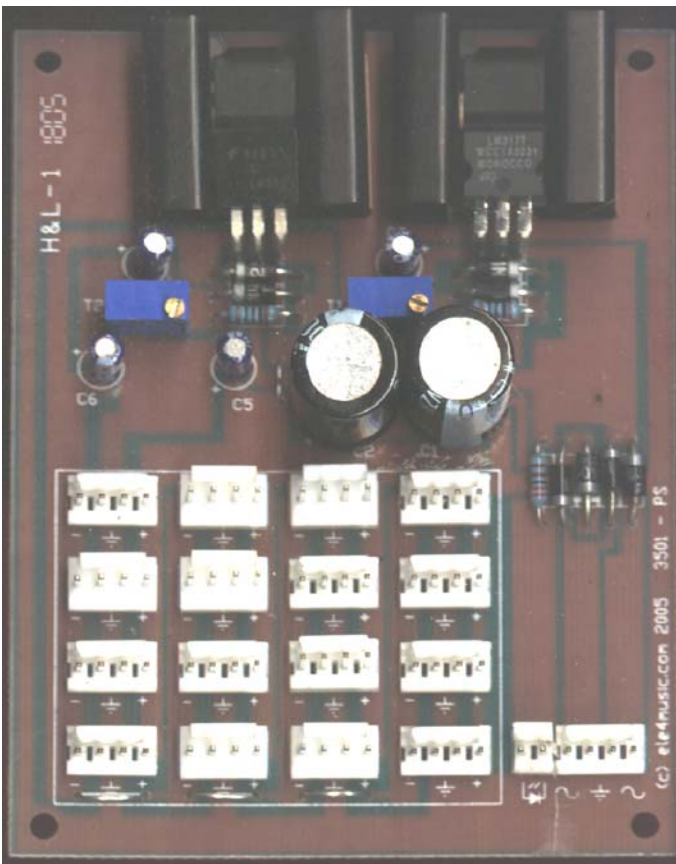

### Description

The power supply provides plus and minus 12VDC. When S1 is closed line level AC is applied to the 24V center tapped transformer. R1 and LED1 form a power on indicator. D1-4 form a full wave rectifier supplying about +/- 18VDC at filter capacitors C1 and C2. U1 is a variable-output positive voltage-regulator. R2 and T1 form a voltage divider C4 is used as a capacitance multiplier. The voltage at the R2-T1 junction determine the regulators output voltage. D5 and D6 are for short circuit protection. Likewise U2 is a variable-output negative voltage-regulator. R3 and T2 form a voltage divider and C3 is used as a capacitance multiplier. D7 and D8 are for short circuit protection.

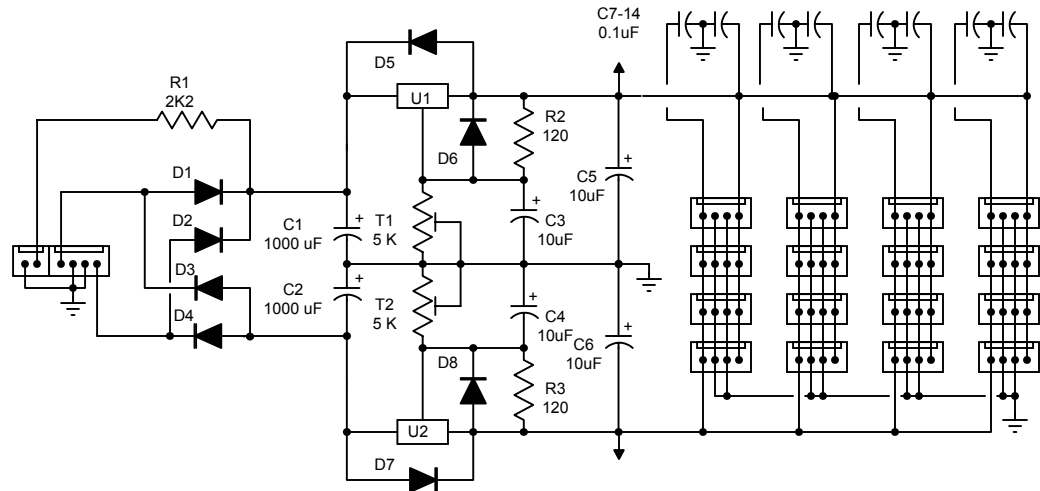

**Setup**

Equipment: Digital Multimeter

- Set your meter to DC-Voltage and attach your probes. Turn S1 on and look for DC voltage on the power headers. You should see something. If not check for DC voltage at D1 and D4.
- Adjust T1 for +12V and T2 for -12V.

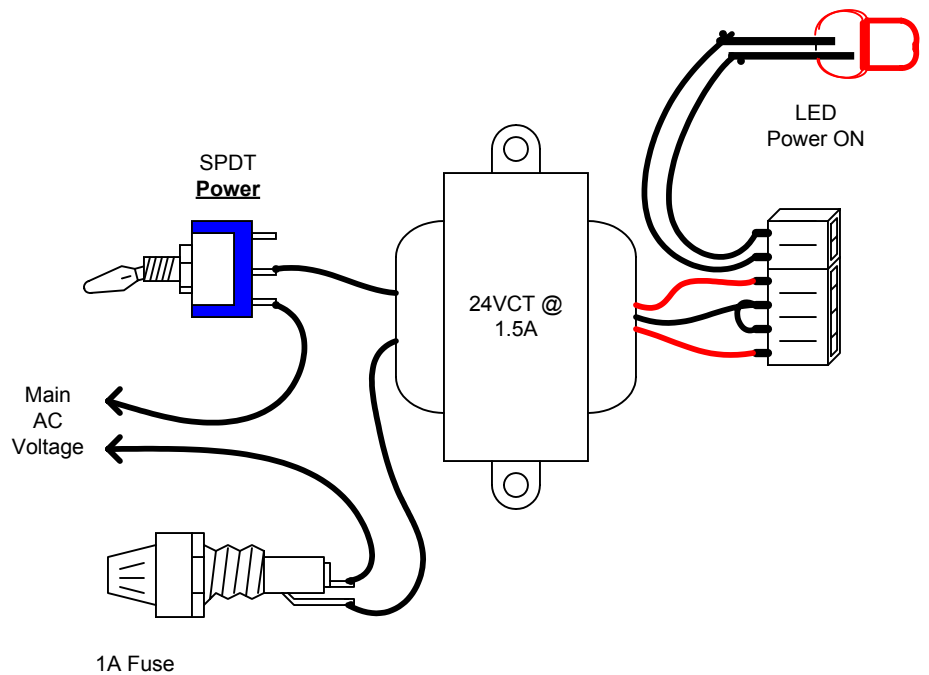

**Small Parts**

R1	2K2	1
R2,3	120 ohm	2
T1,2	5K 10T trimmer	2
C1,2	1000uF 35V ele	2
C3,4,5,6	10uF 35V ele	4
C7-14	0.1uF Ceramic	8
D1-8	1N4001 Diode	8
LED1	LED	1
U1	LM317	1
U2	LM337	1

**Full Parts**

S1	SPST Switch	1
	L Bracket w/hardware	2
	Headers	18
	Panel	1
	Overlay	1

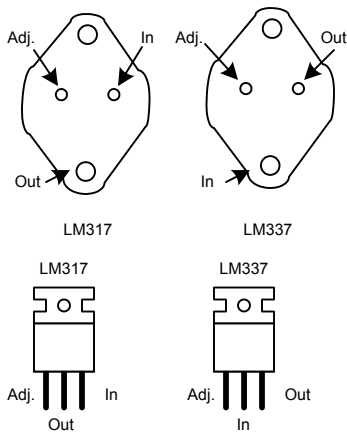

**Hookup**

You'll need some 2 or 3 conductor wire. Use multi strand cable. We don't recommend solid copper wire, it will break.

Measure out a piece strip and tin your wires. Then solder the pins and insert them into the friction-lock connector shell.

If you use three conductor wire you'll have a ground and neutral wire.

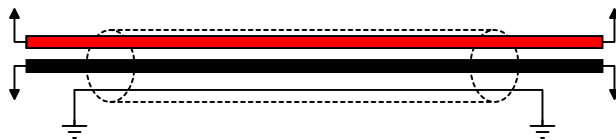
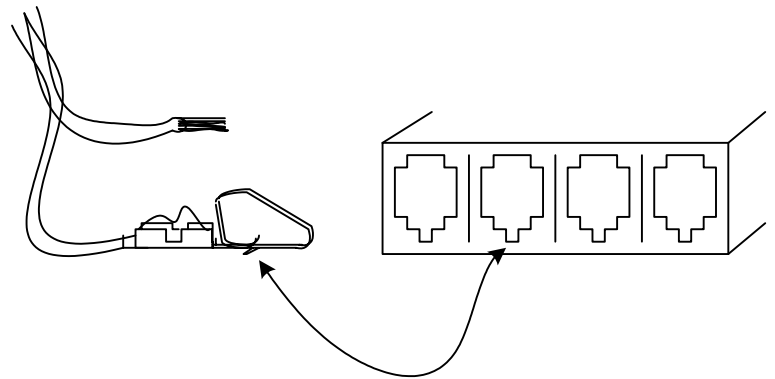
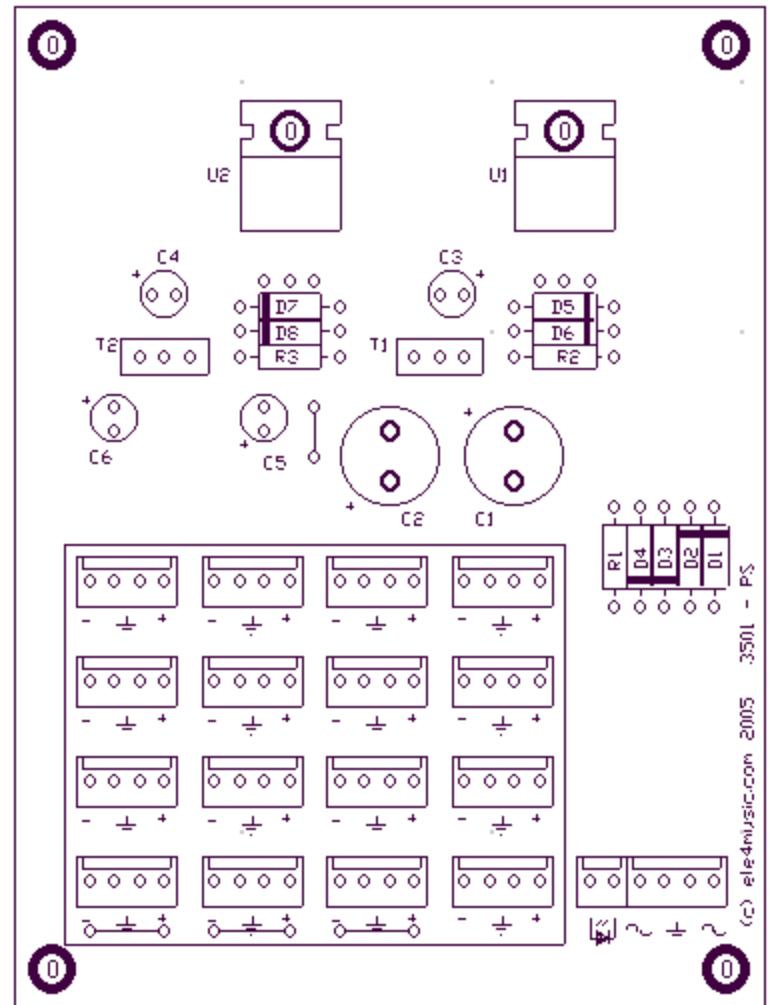

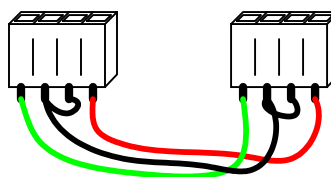
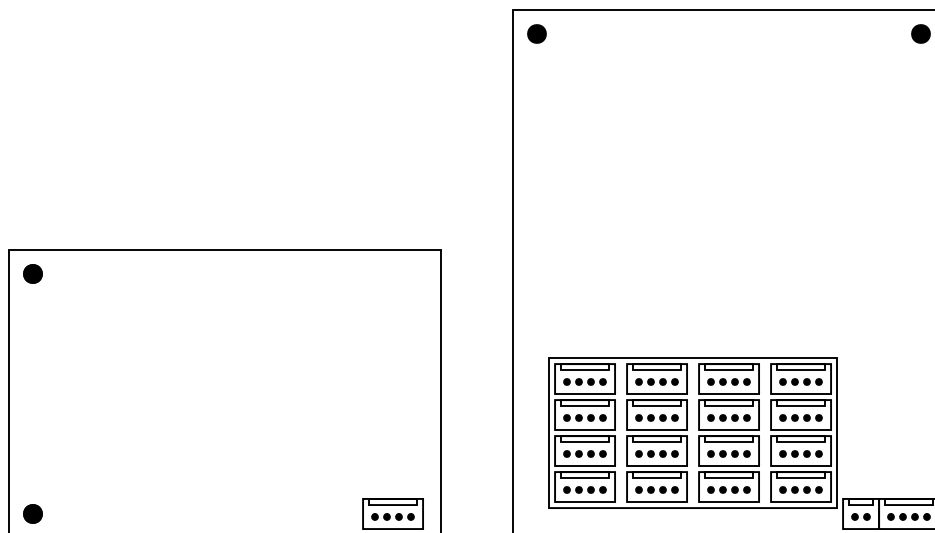

**Hookup Cont.**

Be sure to connect right most pin to positive. The center two pins to ground and the left most pin to negative.

2 Conductor

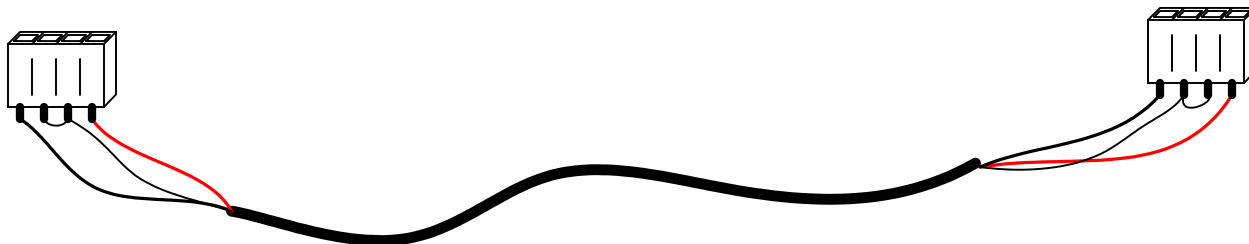

3 Conductor

